

# Hyper Keyboard Pi +F

Raspberry Pi with LCD, game pad and full keyboard to make it a hand-held computer.

2019/9/27 RevA

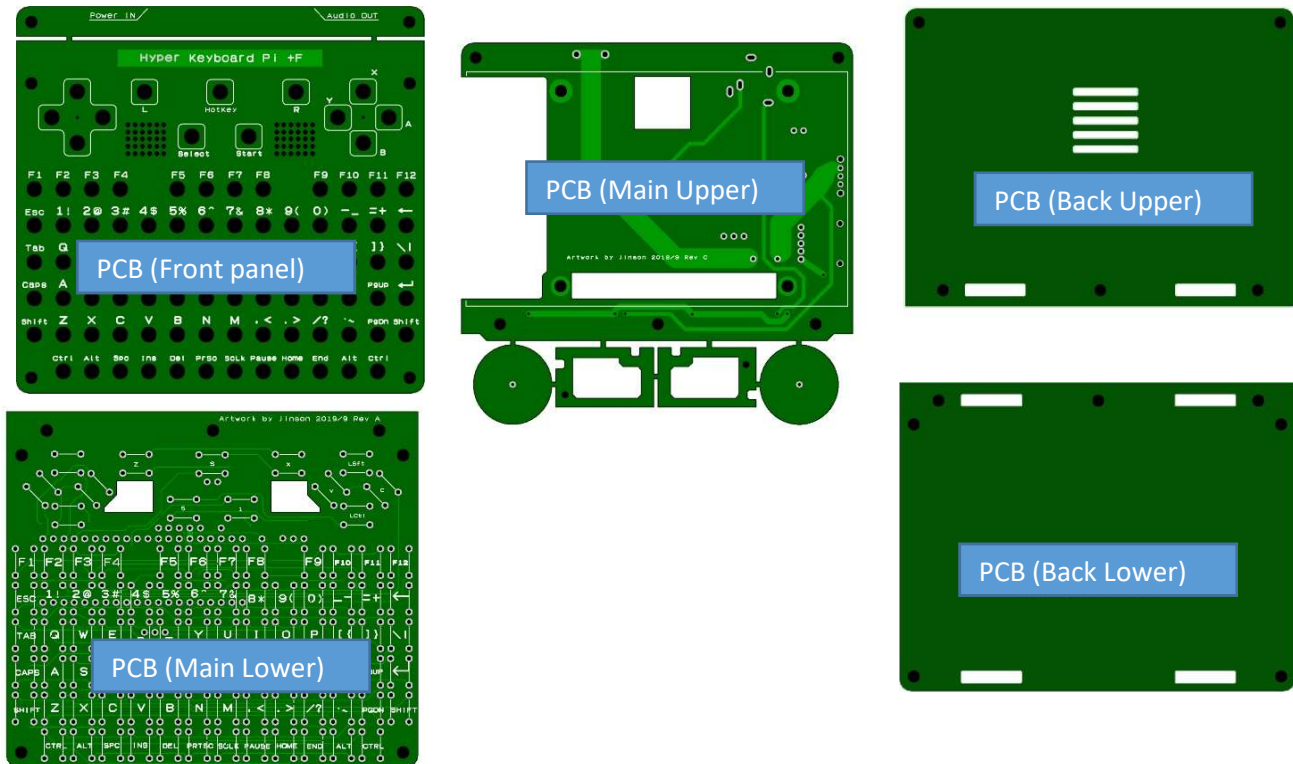

## Feature

- This kit which make raspb3 a hand-held computer
- support raspbian and other OS.  
however its limited to those hyperpixel4.0 supported OS.
- compact size. 15cm x 10cm
- As we adopt HyperPixel 4.0, we can enjoy high-definition, big screen (4 inches)
- Since the surface mounting parts with thin legs are not used,  
it is easy to assemble if the procedure is followed.

Author page: <https://www.telnet.or.jp/~mia/sb/>

## Disclaimer

- 1)This is experimental kit. Not support.
- 2)The completeness of the kit (including operability) is not guaranteed at all.
- 3)Intended for those who can be assembled with reference to this document.  
OS installation can not be supported.
- 4)The author does not bear any responsibility for the accident that accompanies the use of this kit.  
AT YOUR OWN RISK.
- 5)The copyright of this board is not relinquished. Prohibit sale with the same artwork.
- 6)The sound output produces noise when silent. Please be aware.

I hope you enjoy it after understanding the above :-)  
Author : jinson (@chinjinson)

Parts list		yellow Line parts is not included this kit.
Parts name	memo	qty
PCB (Front panel)	Front cover PCB	1
PCB (Main Upper)	LCD Mount PCB	1
PCB (Main Lower)	Keyboard PCB	1
PCB (Back Upper)	Back cover PCB(Raspberry Pi)	1
PCB (Back Lower)	Back cover PCB(Keyboard)	1
2.6mm x 4mm male-female spacer		4
2.6mm x 6.5mm female spacer		6
2.6mm x 11mm female spacer		3
2.5mm x 12.5mm male-female spacer		4
2.6mm x 17.5mm male-female spacer		2
2.6mm x 4mm low head screw		15
2.5mm x 6mm screw	It comes with HyperPixel4.0	4
2.6mm x 4mm screw		3
2.6mm x 6mm screw		3
2.6mm nut		3
2.6mm x 0.2mm washer		4
2.6mm x 1mm washer		4
Dial VR 10K		1
3.5mm stereo mini jack		1
Micro USB connector		1
Slide Switch		1
1.5K	1/8W	1
100K	1/8W	1
0.1uF		3
0.33uF		1
2.2uF		1
10uF/16V		1
3.3V regulator	NJM2845DL1-33	1
Oscillator 6MHz		1
Speaker (2415 size)		2
HT82K629A	Keyboard controller	1
Head Phone AMP PCB	TDA1308 Small RED PCB	1
tactile switch	cosland DTS-63. <a href="https://www.cosland.com/newproduct/DTS%20SERIES.pdf">https://www.cosland.com/newproduct/DTS%20SERIES.pdf</a>	93
4inch LCD	HyperPixel 4.0 Touch- Hi-Res Display for Raspberry Pi	1
RaspberrPi 3B or 3B+		1

OS Installation (it is not support!!)

Can useable hyperpixel4.0 supported OS.

<https://shop.pimoroni.com/products/hyperpixel-4>

Driver is can find below.(This kit is 180 Degree Rotation.)

<https://github.com/pimoroni/hyperpixel4>

At the first, separate the parts from the board and file them to finish.

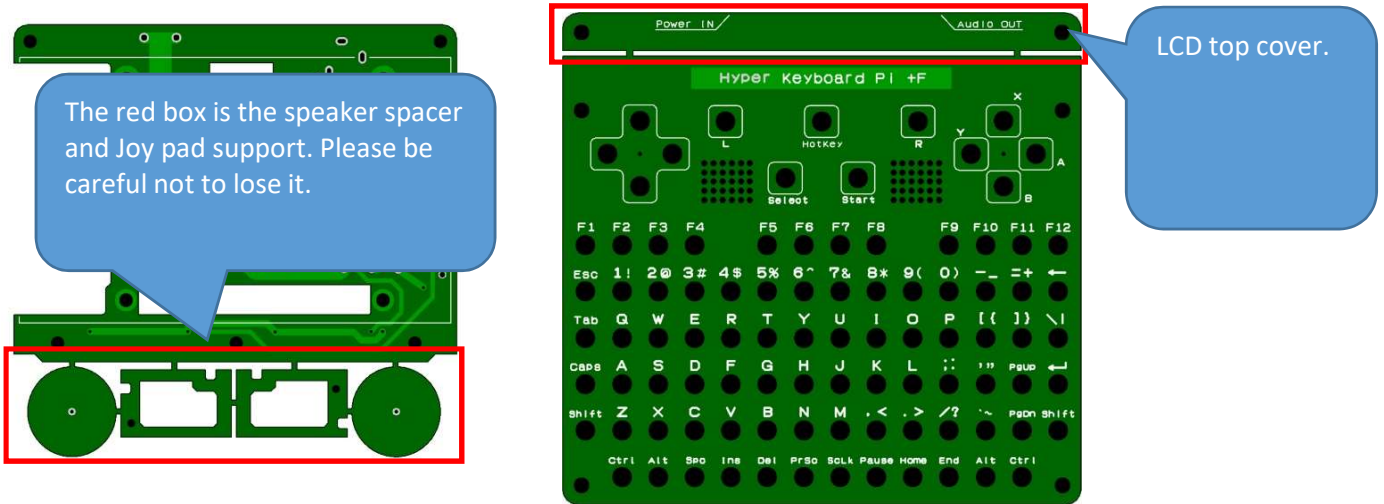

Mount the parts on the back of PCB (Main Upper).

Cut the legs so that does not come out of the board surface.

Mount "Head Phone AMP PCB" with parts legs wire.

Back Side

Front Side

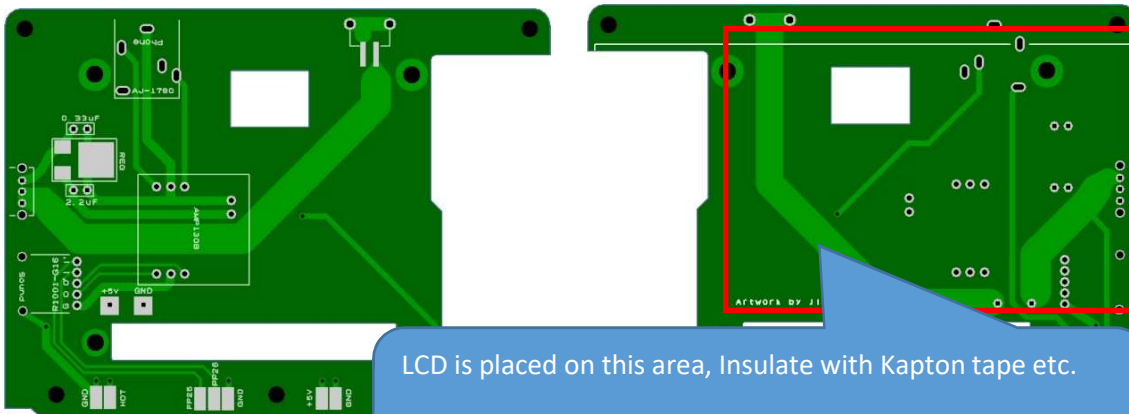

**Be sure to insulate.**

Next, assemble the keyboard.

Insert the HT82K629A on the Back of PCB (Main Lower).

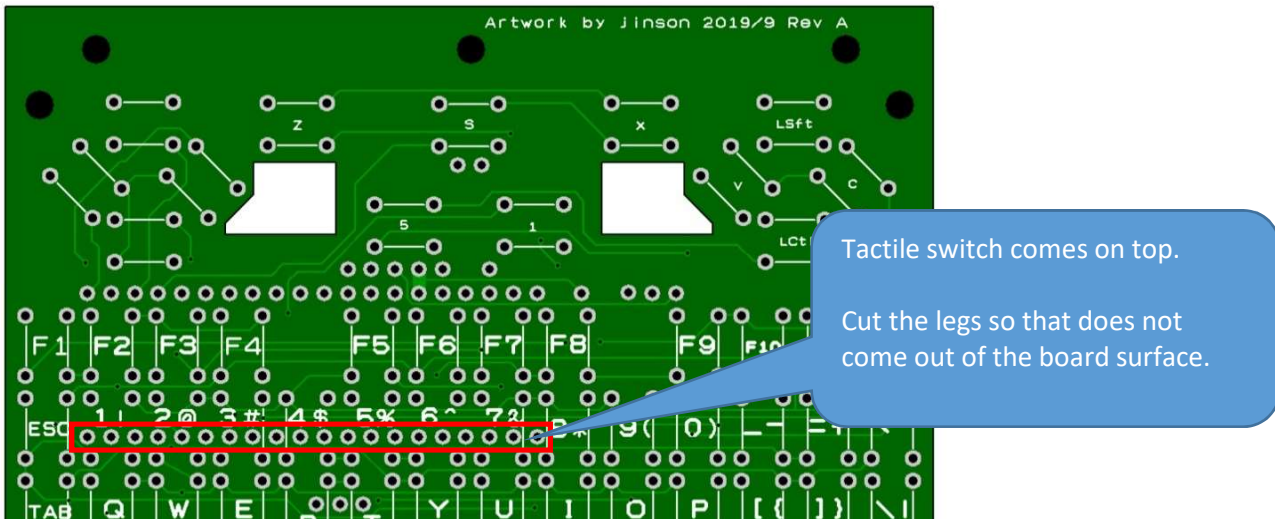

The cut is complete, remove the HT82K629A. Do not solder at this stage.  
 Insert the tactile switches on the Front of PCB (Main Lower).

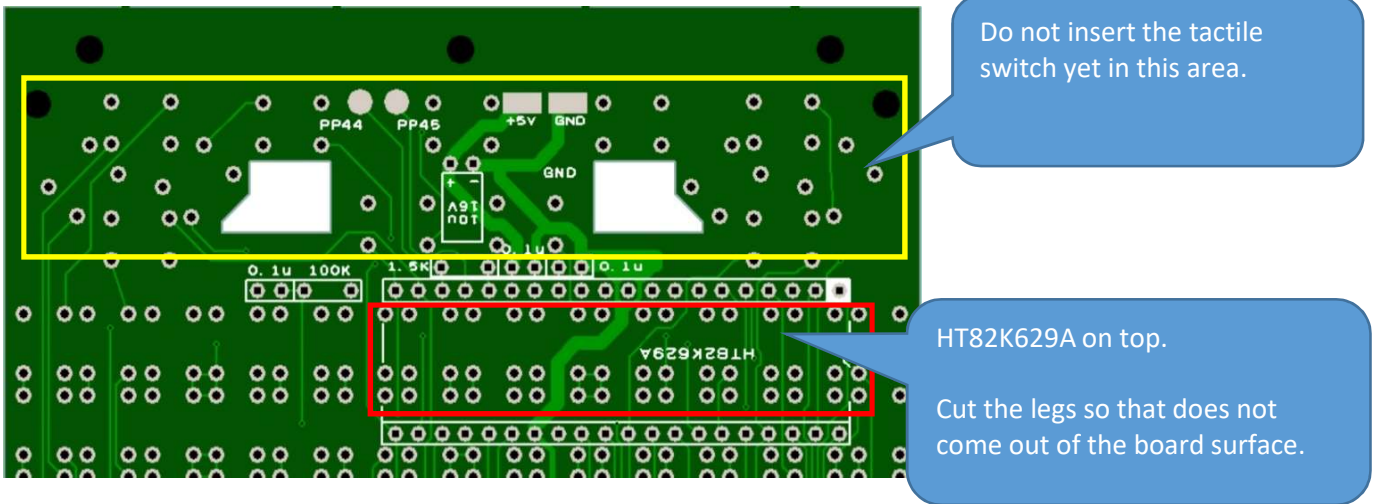

Put the front panel board and check the tactile switch shift. Solder the tactile switch if its OK.

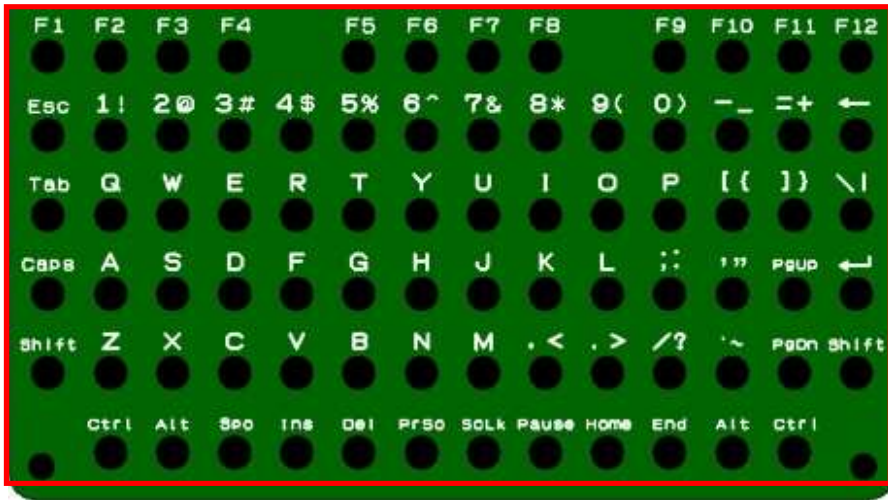

When soldering of the tactile switch is complete, Insert the HT82K629A and perform soldering.  
 HT82K629A solders not from the back side, but from the component side. Be careful as this is likely to cause poor solder.

After that, mount Oscillator, capacitor, registers.

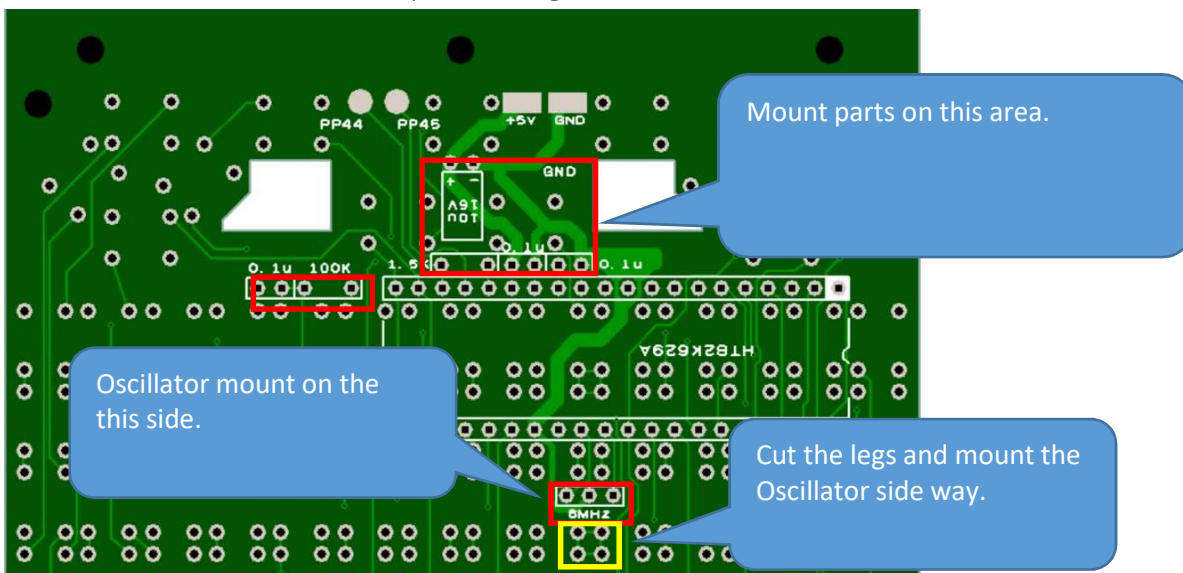

Next, assemble the Joy Pad.

There is no part to consider. Put the front panel board and check the tactile switch shift.

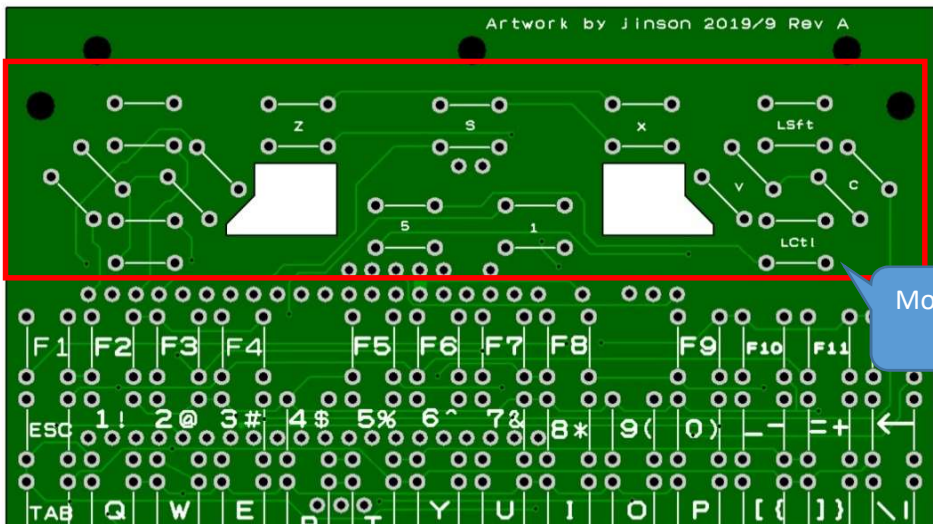

Mount tactile switch this area.

Combine PCB (Main Upper) and PCB (Main Lower) using 2.6mm x 6mm screw and nuts.

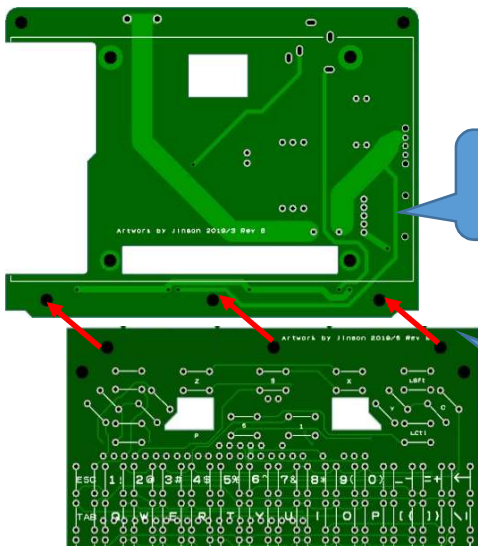

PCB (Main Upper) is bottom.

insert 2.6mmx6mm screw and fix PCB (Main Upper) back side with nut .

Connect Speaker and other.

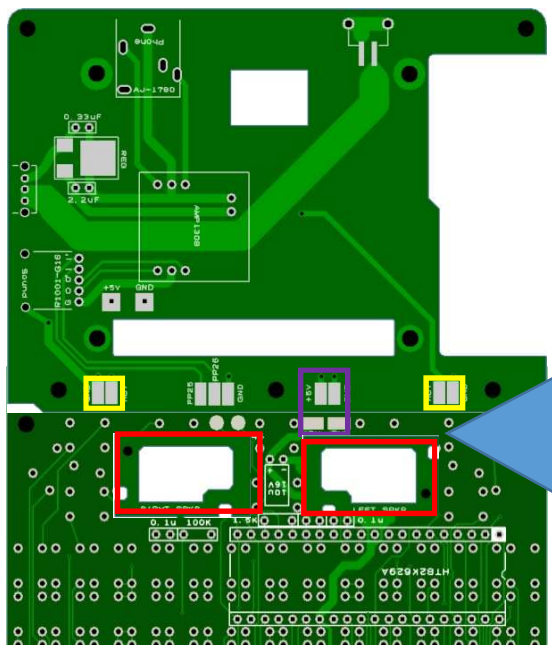

Mount the speaker spacer, which has been separated in advance, with adhesive tape to the speaker hole position. If the legs of the tactile switch comes out of the Speaker spacer board surface, cut it.

Mount the speaker with adhesive tape, and wire the speaker to the pad part of the yellow frame.

Use the terminals in the purple frame to connect the upper board to the lower board.

Mount LCD on the PCB (Main Upper) and fix back side with spacer.

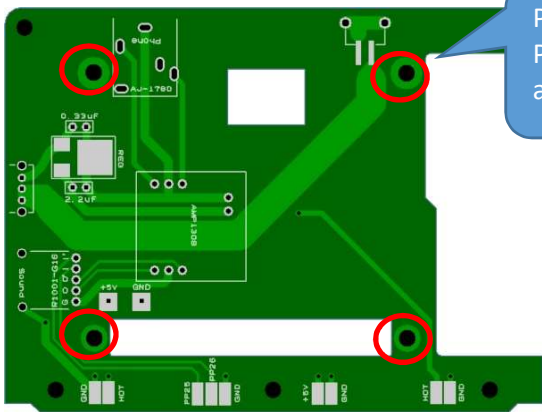

Place a 2.6mm x 0.2mm washer between the LCD and the PCB. Put a 2.6mm x 1mm washer in 2.5mm x 12.5mm male-female spacer, and then fix the PCB and LCD.



Make a connection of Raspi. Pull out the wire before connecting.

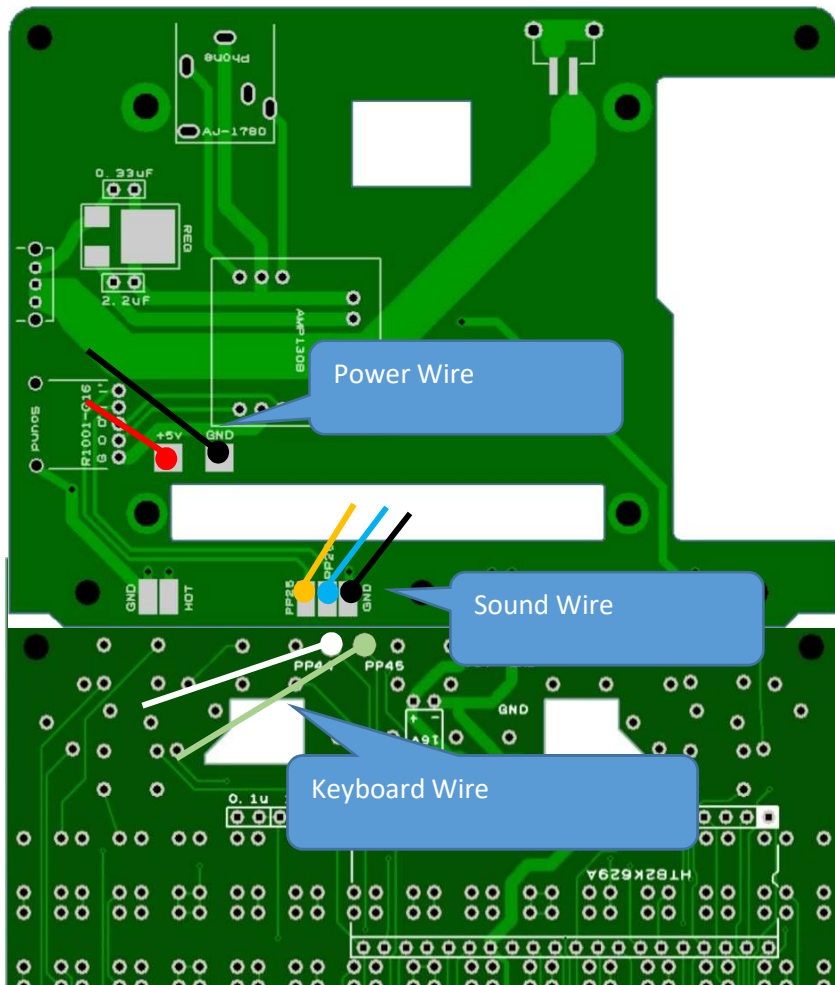

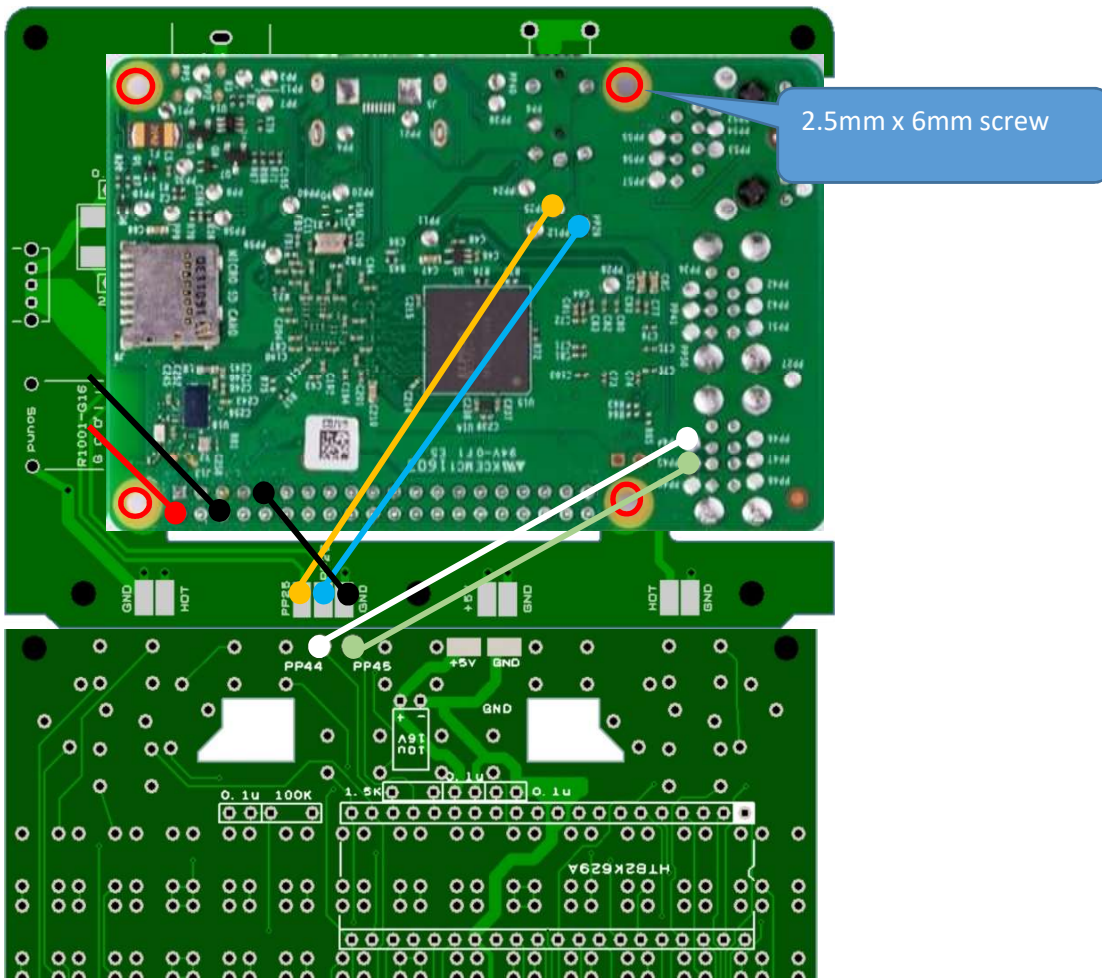

mount spacers

Front side

Back side

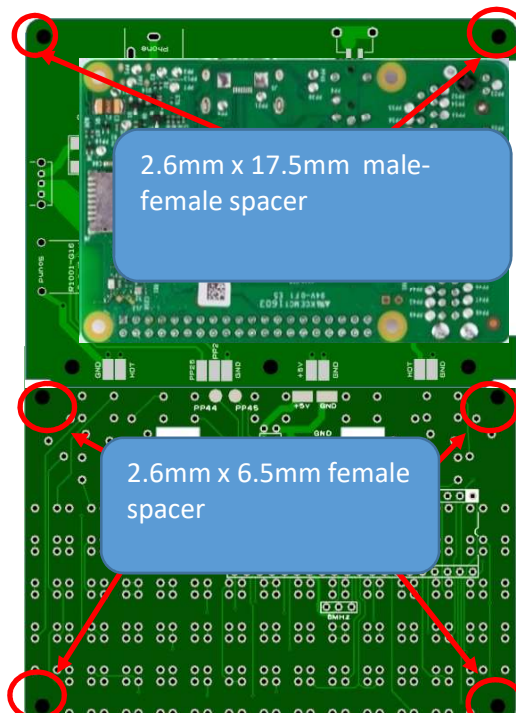
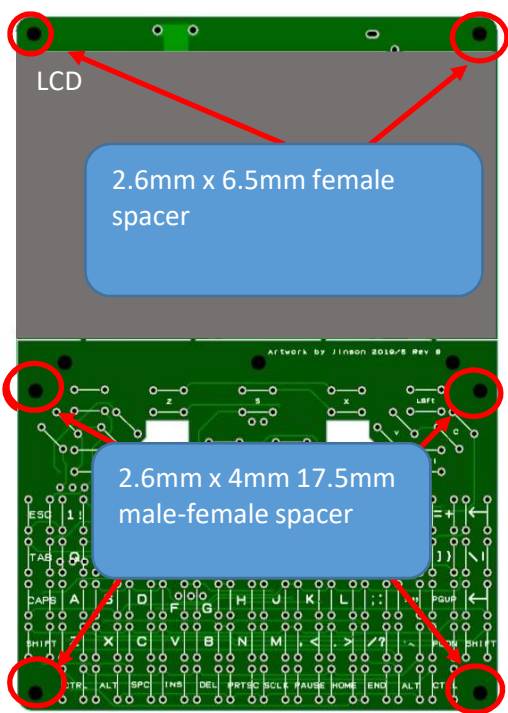

Back Cover

Connect the board using the 2.6mm x 11mm female spacer

2.6mm x 4mm low head screw

2.6mm x 4mm screw

complete!

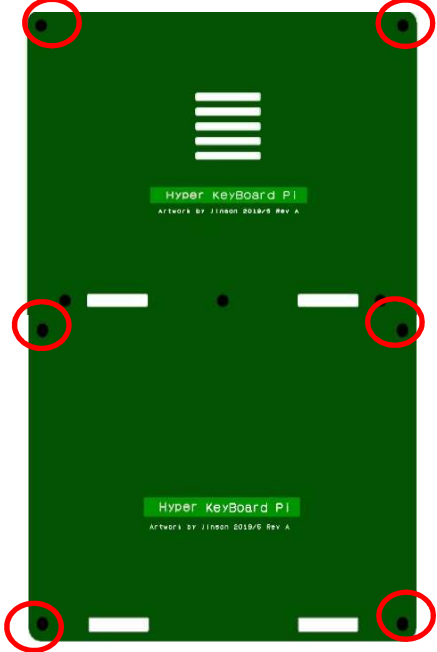
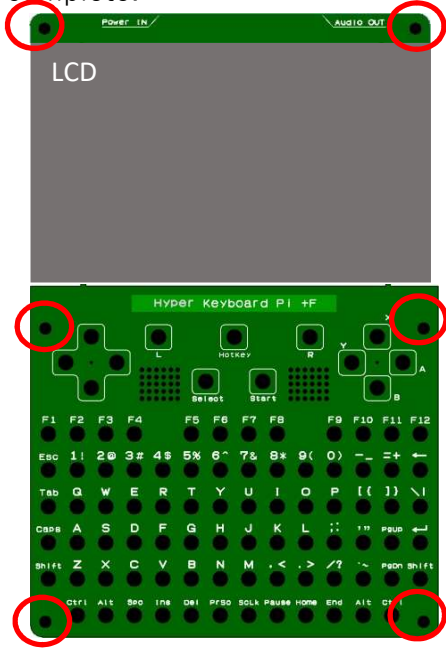

All 2.6mm x 4mm low head screw

Joy pad support

Solder the legs of capacitors or resistors.



After soldering, cut and insert appropriate lead wire coating to about 2 mm

Insert it into the PCB (Front panel) and push it so that the gap between the joy pad and the PCB (Front panel) is about 1.5 mm.

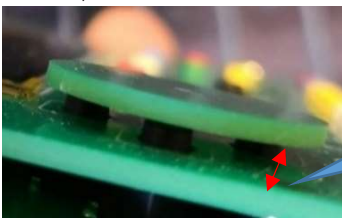

About 1.5 mm. There is no gap between it and the tactile switch

At the back of the PCB (Front panel), fold the wires.



Fold the wire in about 2 mm length. and adjust your feel.

thanx!